

HY-330

fall semester 2021

Introduction to telecommunication systems theory

University of Crete
Computer Science Department

Stefanos Papadakis

Coding

- ✦ Channel Coding:
 - ✦ Forward Error Correction (FEC)
 - ✦ Error-Correcting Code (ECC)

Gray Code

- Two successive values differ in only one bit
- Points in constellations follow grey code mapping
- Why?
 - Think of the symbol vs. bit error rate

Gray Code

Decimal	Binary	Gray
0	000	000
1	001	001
2	010	011
3	011	010
4	100	110
5	101	111
6	110	101
7	111	100

Constellation Diagram

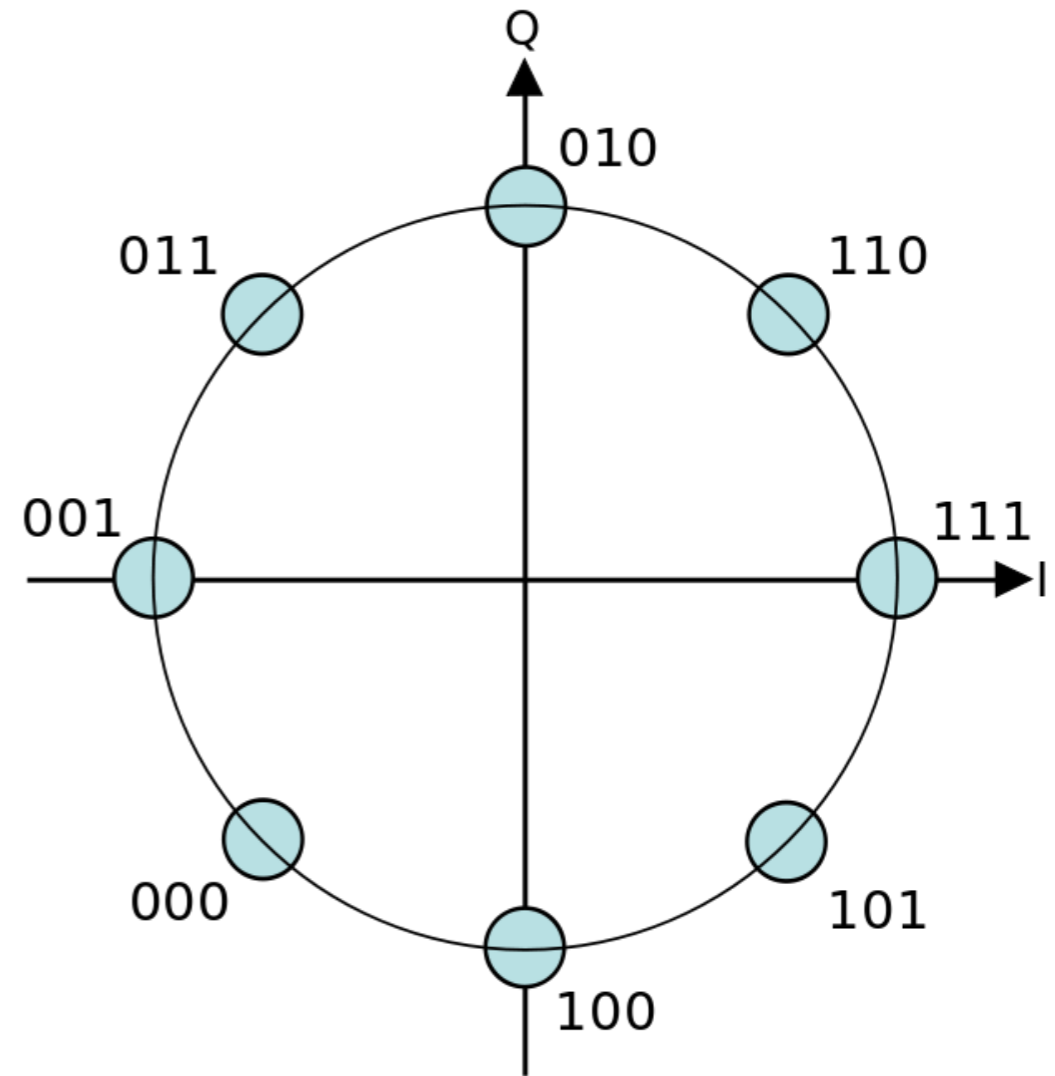
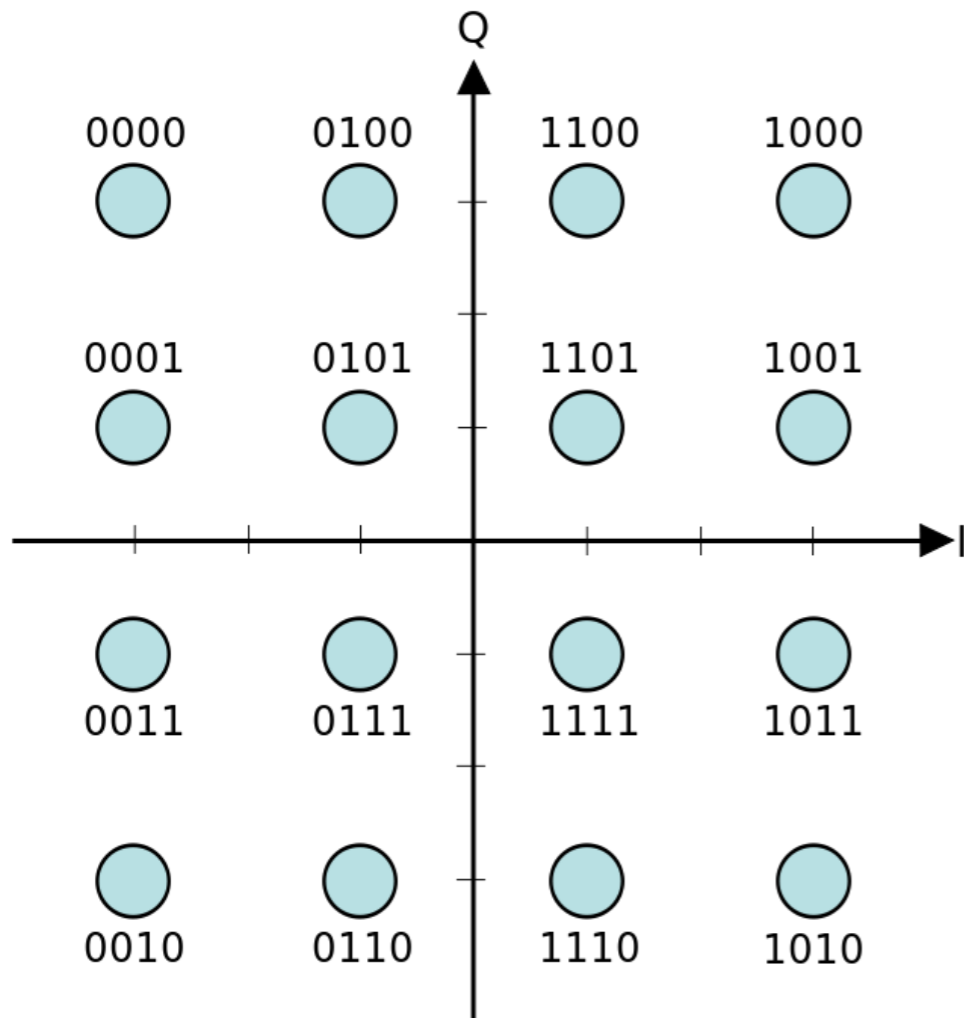

Hamming Distance

- ✦ Two strings of equal length
- ✦ The number of positions at which the corresponding symbols are different
- ✦ Examples:
 - ✦ 110100110 - 110001010: hamming distance = 3
 - ✦ Tooth - Booth: : hamming distance = 1

Hamming Distance

- ✦ Binary strings is a special case
- ✦ Hamming distance = XOR + count ones
- ✦ Example:
 - ✦ $110100110 \oplus 110001010 = 000101100$
 - ✦ $000101100 \Rightarrow 3 \times 1$

Hamming Distance

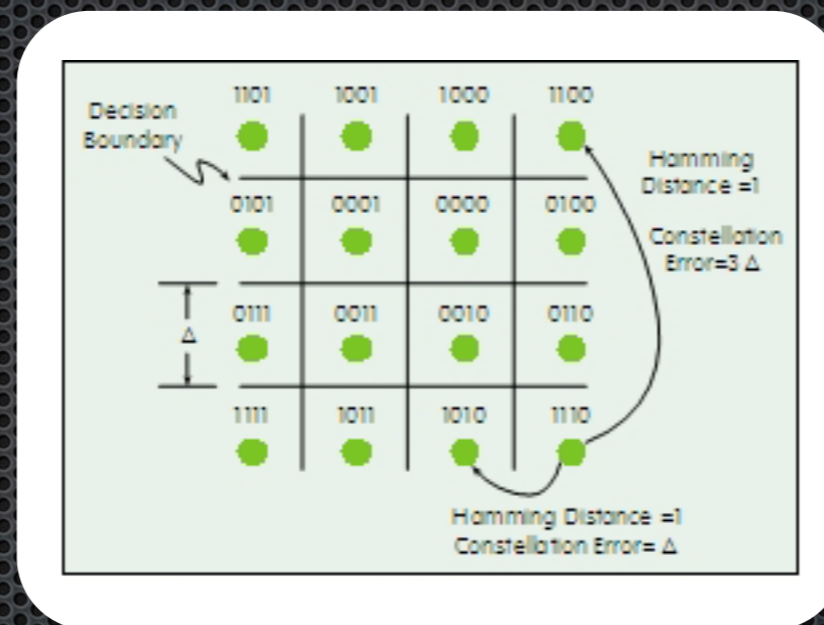

Error Detection

- ✦ Detect an error has occurred
- ✦ Error detection \neq Error correction
- ✦ Detection can not tell the position of the error

Parity

- Make sure the number of 1 bits is either even or odd
- Add one bit to provide the parity
- Detects one (actually odd number) bit alteration

Original Data	Even Parity	Odd Parity
0 0 0 0 0 0 0 0	0	1
0 1 0 1 1 0 1 1	1	0
0 1 0 1 0 1 0 1	0	1
1 1 1 1 1 1 1 1	0	1
1 0 0 0 0 0 0 0	1	0
0 1 0 0 1 0 0 1	1	0

Hamming Distance

- ✦ Consider an alternate use of additional bits
- ✦ What is the hamming distance of the following codewords?

Dataword	Codeword
0 0	0 0 1
0 1	0 1 0
1 0	1 0 0
1 1	1 1 1

Hamming Distance

min hamming distance: d_{min}

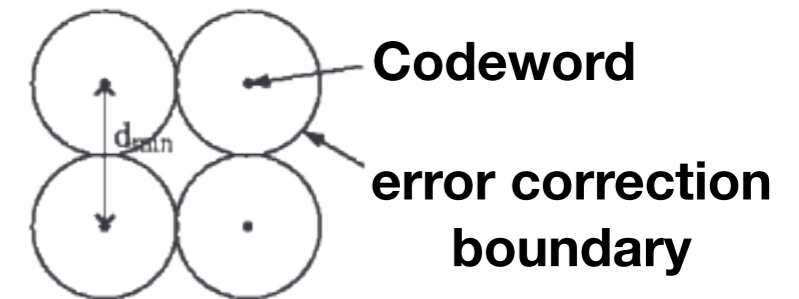

✦ Error Detection: max $d_{min} - 1$ bit errors

✦ Error Correction: max $\left\lfloor \frac{d_{min} - 1}{2} \right\rfloor$ bit errors

Forward Error Correction

FEC is based on redundancy

Codes->

- systematic: original information + extra information
- non-systematic: completely different output

Forward Error Correction

Categories of Codes:

- block: use fixed-size blocks (chunks) of bits
 - hard-decision
- convolutional: are applied on continuous stream of bits
 - soft-decision
- concatenated: combined block & convolutional
 - for high erroneous channels (e.g. deep space)

Block codes

- ✦ Hamming
- ✦ Reed-Solomon
- ✦ Golay
- ✦ BCH

Convolutional codes

- ✦ boolean polynomial
- ✦ decoding: trellis (Viterbi)
- ✦ code rate increase: symbol puncturing

Convolutional codes

encoding:

- ✦ recursive
- ✦ non-recursive

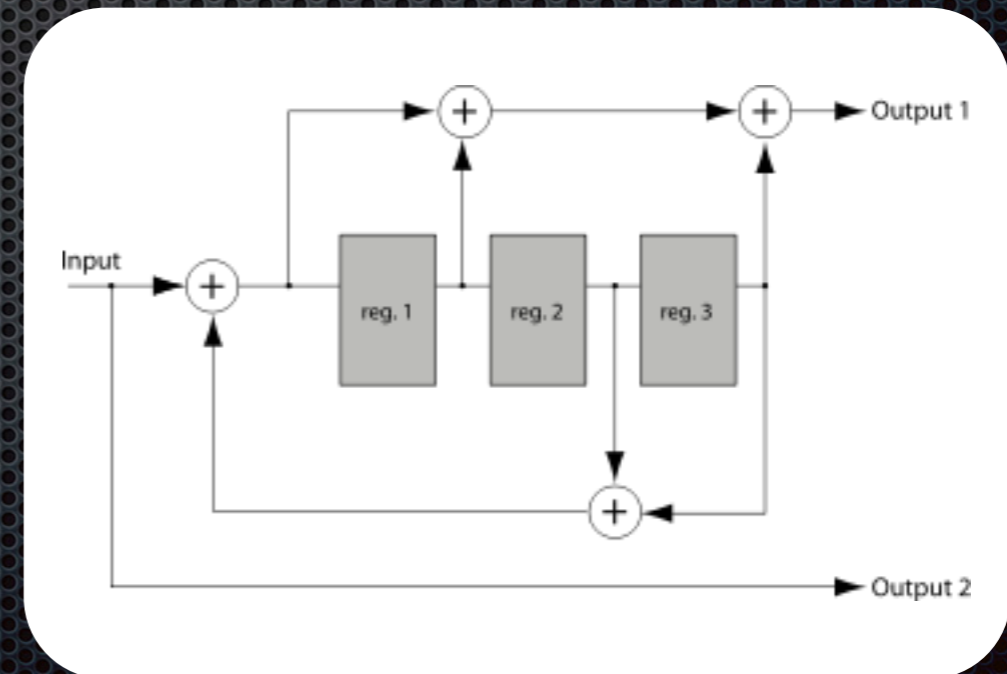
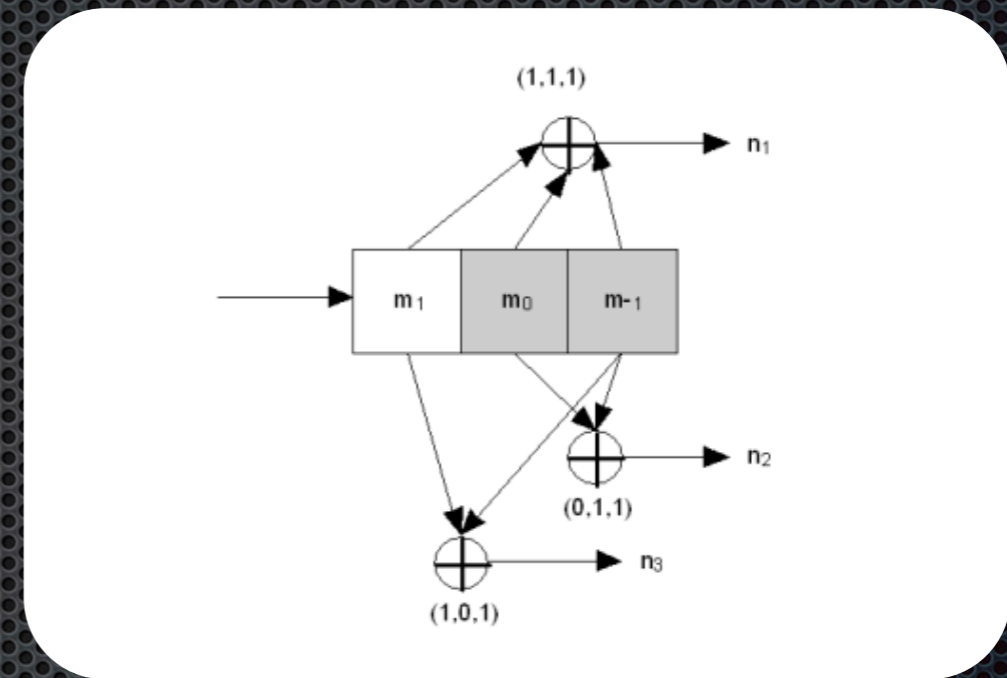

Convolutional codes

decoding:

- ✦ trellis diagram
- ✦ Viterbi algorithm

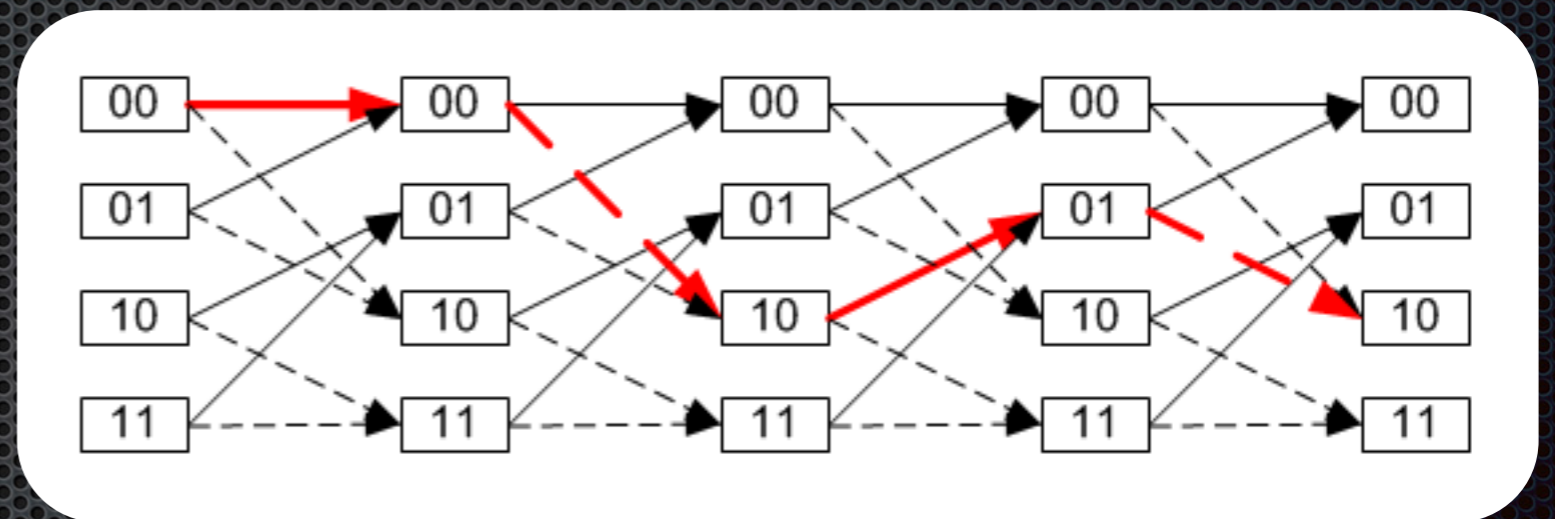

Interleaving

- What is more probable to happen:
 - nicely distributed errors or bursts of errors?
- Consider this message: ThisIsAGoodExample
- Interleaved: TlOxlhsoaeiAdmsGEp
- Rx non-interleaved: ThisIsAxxxxExample
- Rx interleaved: TlOxlhsxxxxAdmsGEp
- Rx de-interleaved: ThxsIsAGoXdExxmplx

Coding Gain

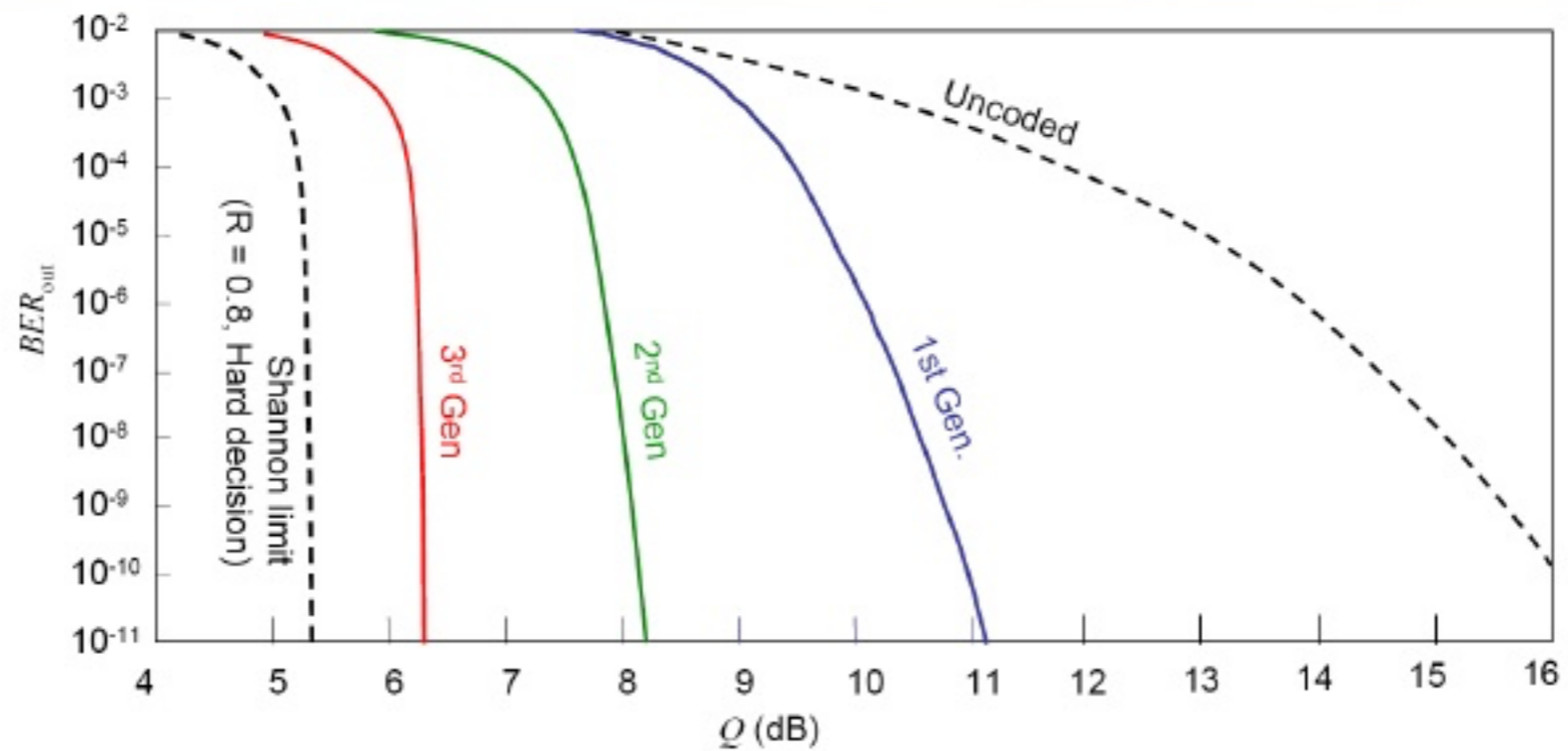

Year	2003	2000	1993
Coding Scheme	Block Turbo Code LDPC	Concatenated RS, BCH	RS(255,239)
Net Coding Gain (@ 10^{-13})	~10dB	7~9dB	5.8dB